



HRL-0300-1-3 HEATLESS DESICCANT AIR DRYER GENERAL ARRANGEMENT

TOLERANCES UNLESS
OTHERWISE SPECIFIED:

- FRACTIONS = ± 1/4 "
- ANGLES = ± 3°
- INCHES = ± 1/2 "
- FINISH = 250

THE SPECIFICATIONS AND DRAWINGS DISCLOSED HEREIN ARE THE SOLE PROPERTY OF ALTEC AIR, AND SHALL NOT BE COPIED OR USED AS THE BASIS FOR SALE OR MANUFACTURE WITHOUT EXPRESS WRITTEN PERMISSION.

REVISION LOG

REV.	ECO.	DESCRIPTION	DATE	APPROVED
B	0661	ADDED BOLT HOLE DIMENSIONS	3/20/2018	WS

DRAWING NO. **AT20-1006** REV. **B**

DRAWN: WS DATE: 6/7/2018
CHECKED: DATE:

SCALE: N/A SHEET: 1 OF 2

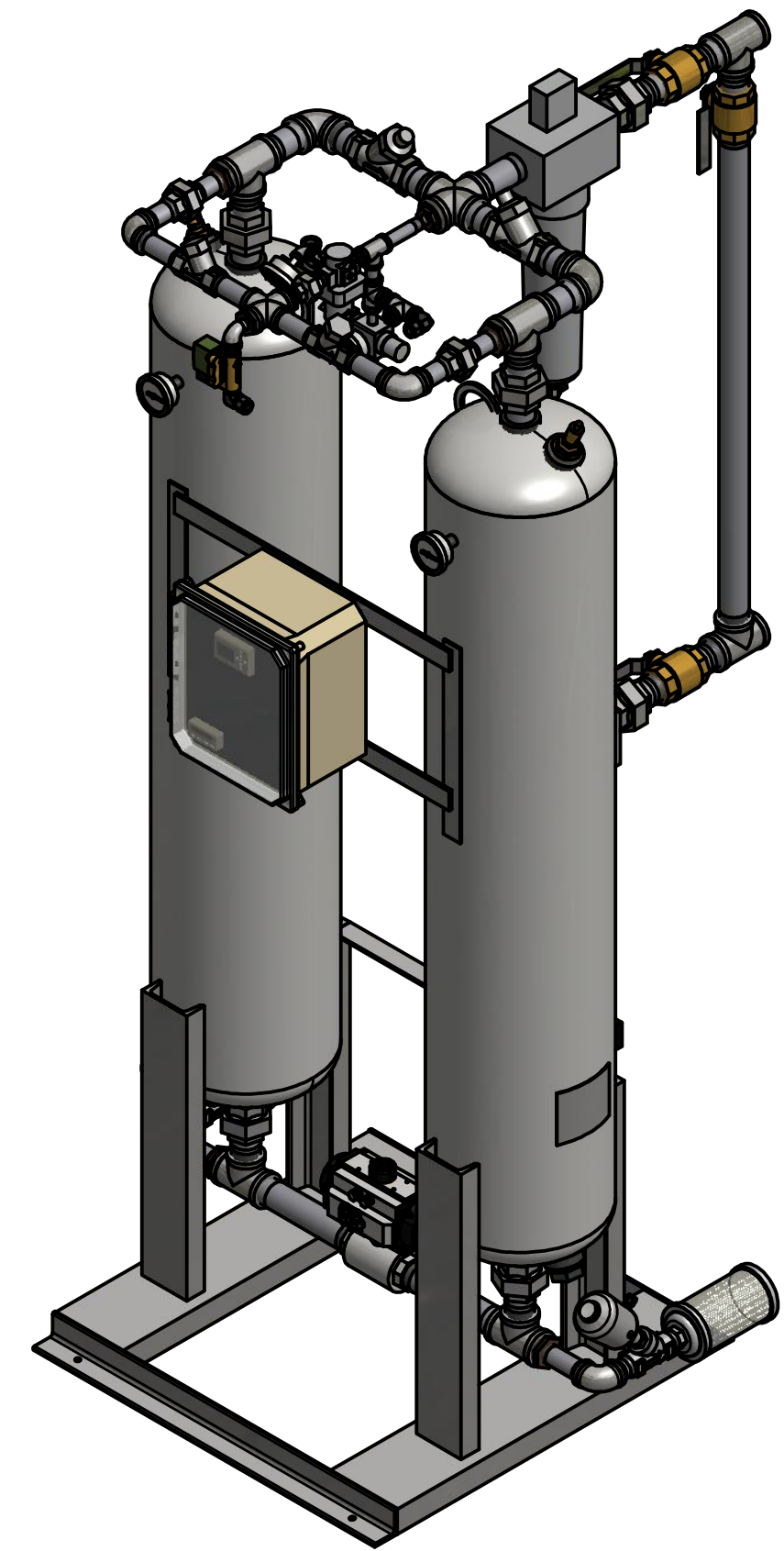
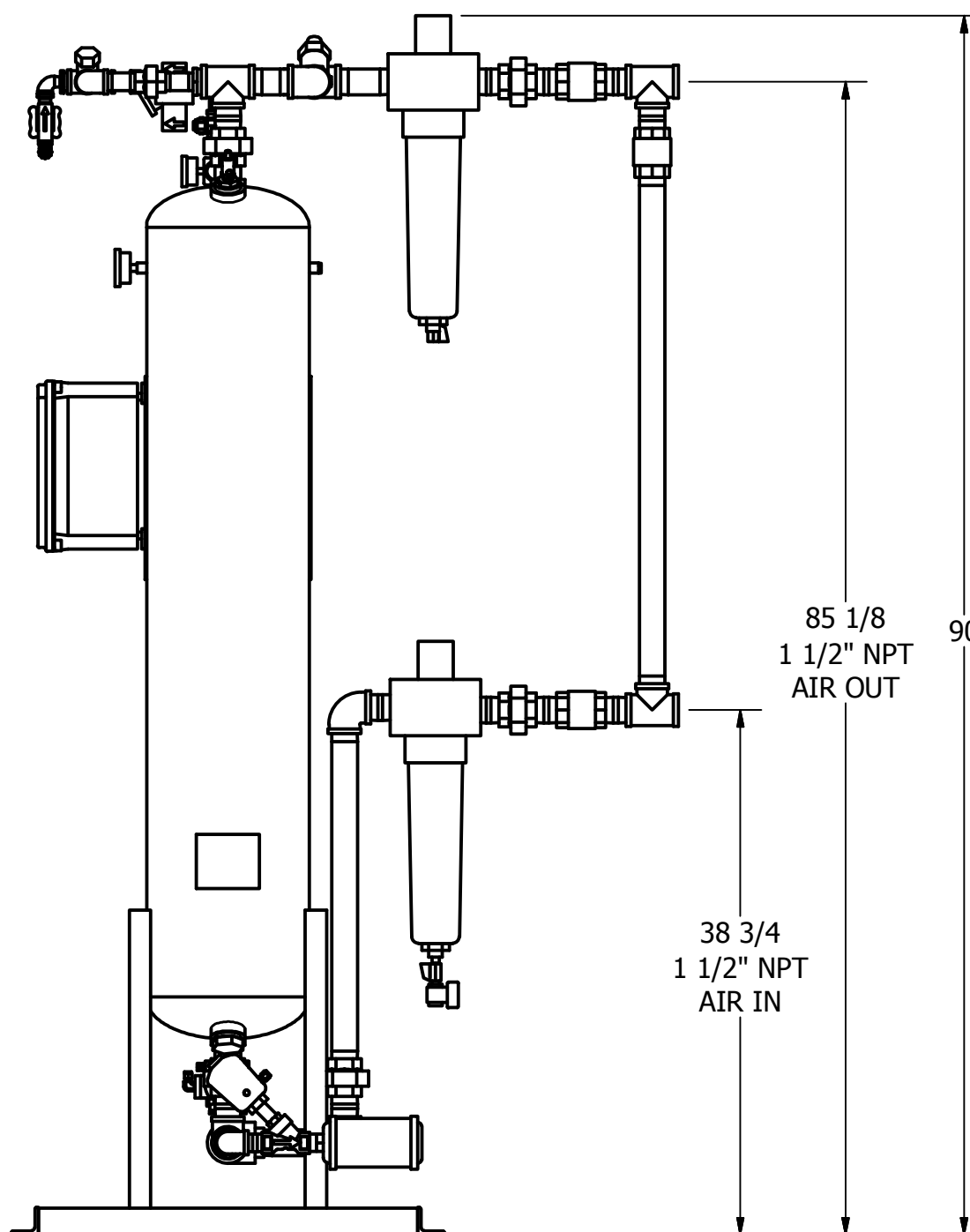
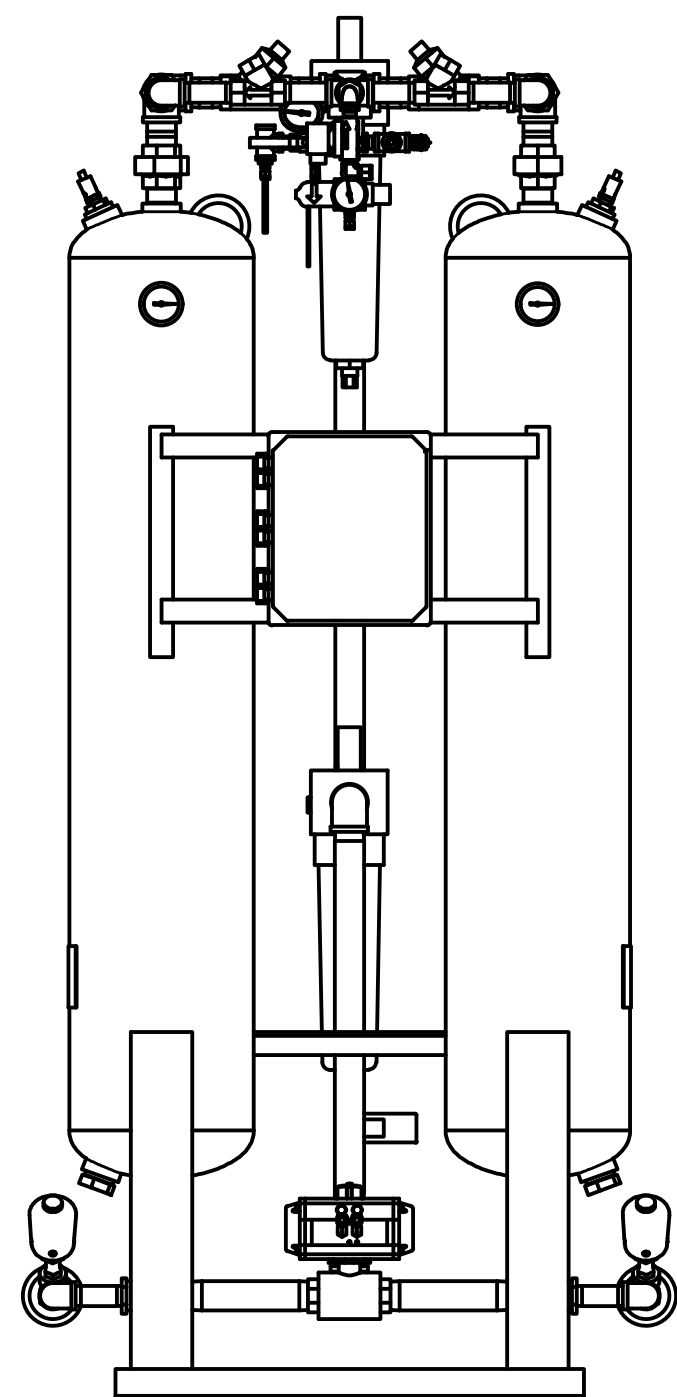
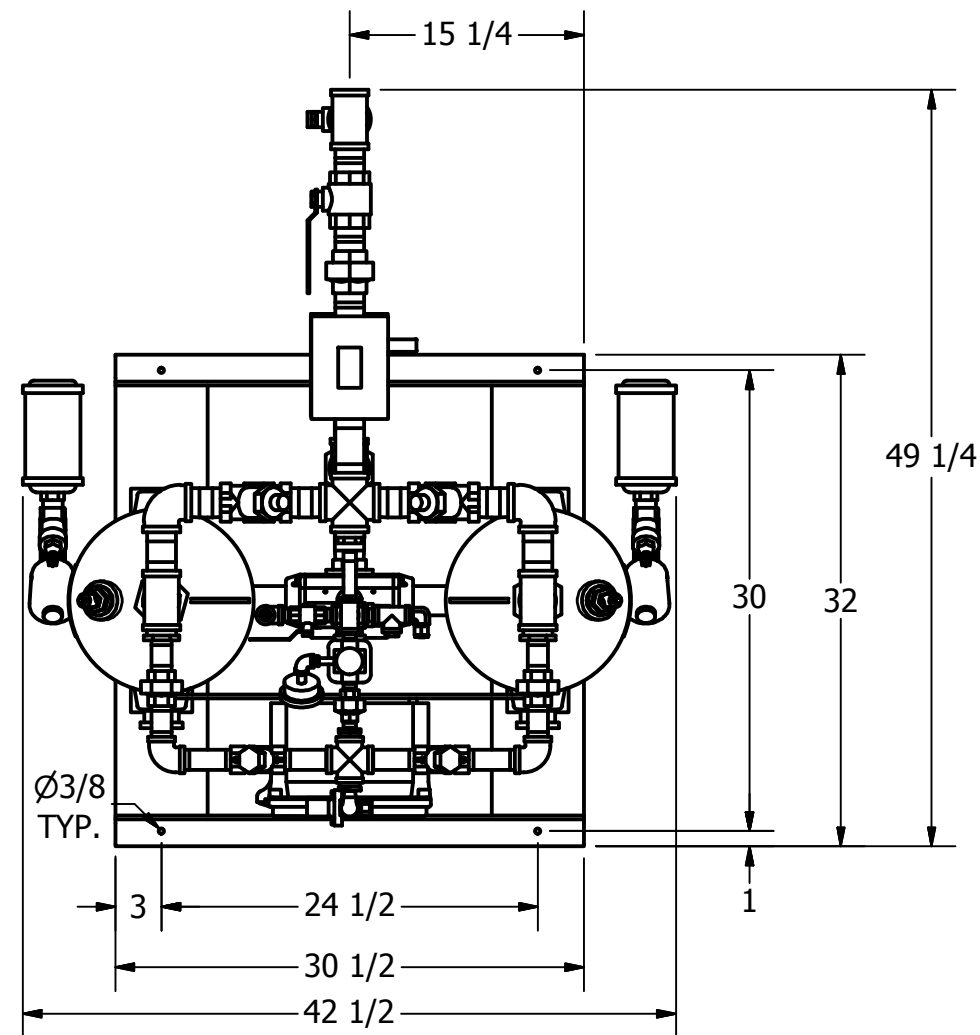

PRELIMINARY



HRL-0300-1-3 HEATLESS DESICCANT AIR DRYER GENERAL ARRANGEMENT

TOLERANCES UNLESS
OTHERWISE SPECIFIED:

FRACTIONS = ± 1/4 "
 ANGLES = ± 3°
 INCHES = ± 1/2 "
 FINISH = 250

THE SPECIFICATIONS AND DRAWINGS DISCLOSED HEREIN ARE THE SOLE PROPERTY OF ALTEC AIR, AND SHALL NOT BE
 COPIED OR USED AS THE BASIS FOR SALE OR MANUFACTURE WITHOUT EXPRESS WRITTEN PERMISSION.

REVISION LOG

REV.	ECO.	DESCRIPTION	DATE	APPROVED
B	0661	ADDED BOLT HOLE DIMENSIONS	3/20/2018	WS

DRAWING NO.

AT20-1006

REV.
B

DRAWN: WS DATE: 6/7/2018
 CHECKED: DATE:

SCALE: N/A

SHEET: 2 OF 2

PARTS LIST

ITEM	QTY	DESCRIPTION
1	2	CHECK VALVE, PURGE
2	1	PRESSURE REGULATOR, PURGE
3	1	PRESSURE GAUGE, PURGE
4	2	CHECK VALVE, OUTLET
5	1	PARTICULATE AFTER-FILTER
6	2	RELIEF VALVE, TANK
7	1	DEW POINT MONITOR (OPTIONAL)
8	1	SOLENOID VALVE, REPRESS
9	1	MOISTURE INDICATOR
10	1	PRESSURE REGULATOR, CONTROL
11	1	PRESSURE GAUGE, CONTROL
12	2	PRESSURE GAUGE, TANK
13	1	COALESCER PRE-FILTER
14	1	TIMED DRAIN
15	1	3 WAY BALL VALVE, INLET
16	2	ANGLE BODY VALVE, EXHAUST
17	2	MUFFLER, EXHAUST
18	3	MANUAL BALL VALVE, BYPASS
19	330 LBS	DESICCANT

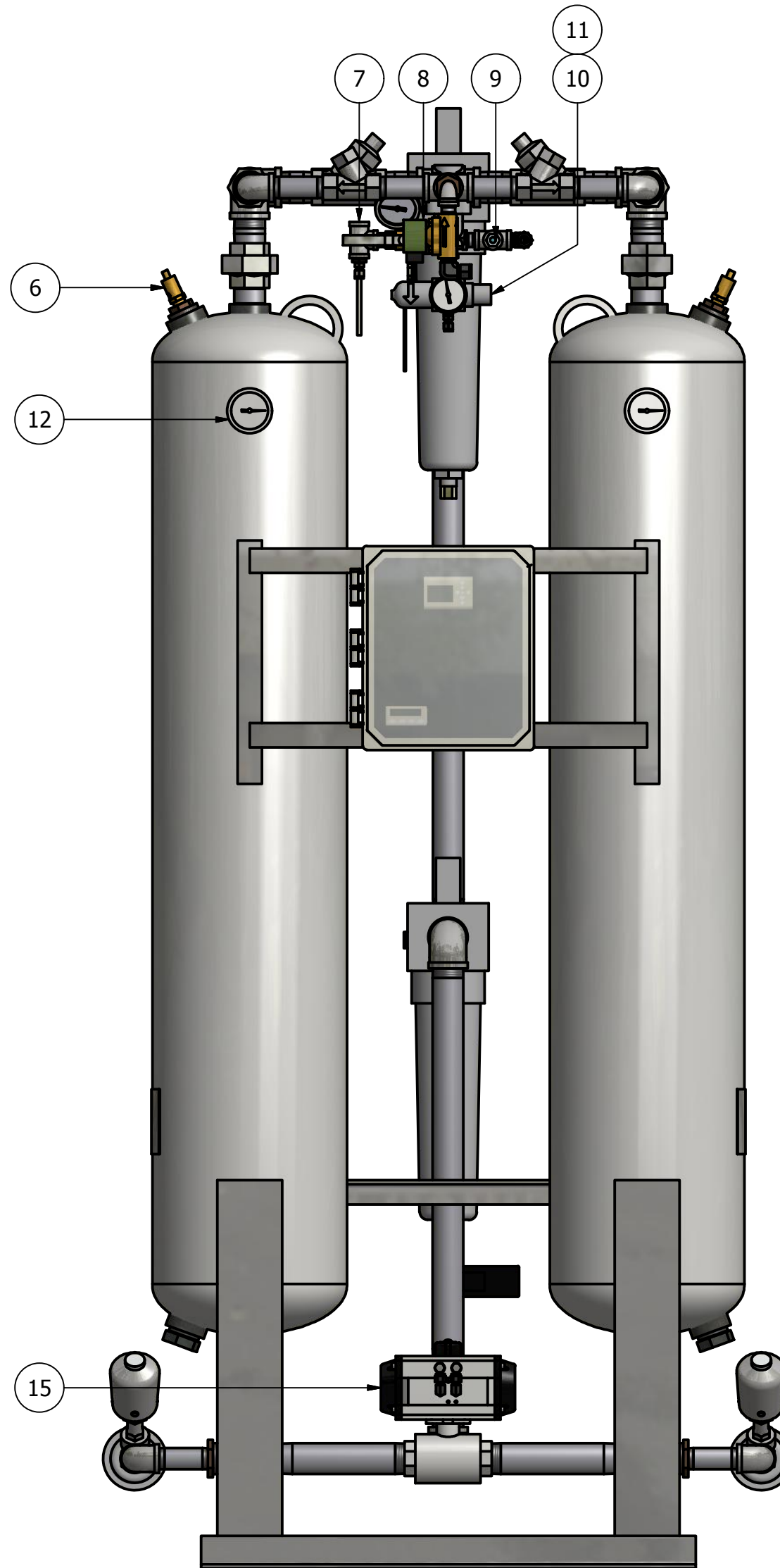
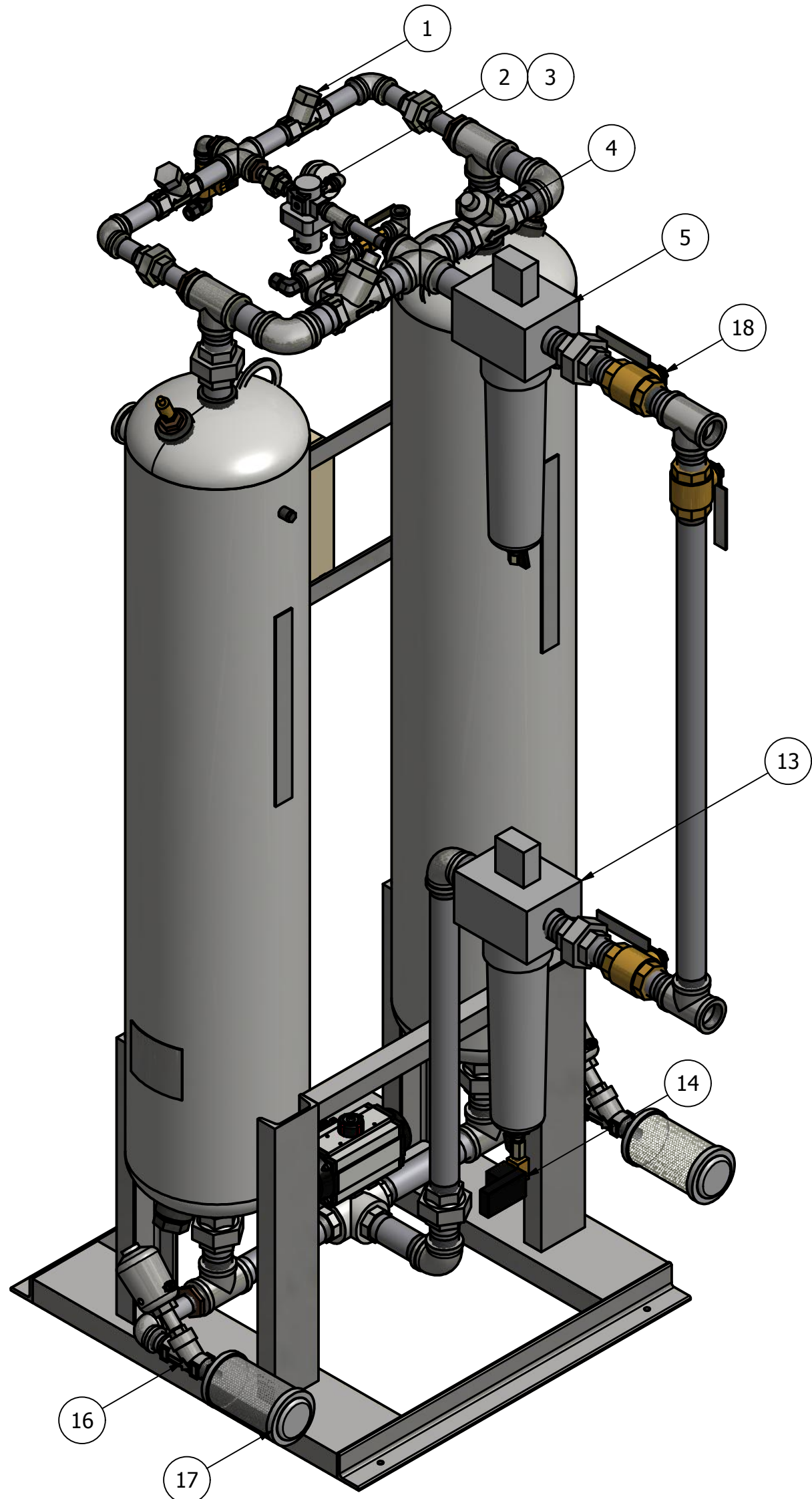

PRELIMINARY